

TB80



**Straight
Boom**



www.snorkelusa.com

Snorkel TB80

| Platform | Machine Dimensions | Performance |
|---------------------------------------|--|---|
| Height80' (24.4 m) | Stowed Length.....38'10" (11.8 m) | Power Source Gas or Diesel |
| Size.....96" x 30" (243.8 cm x 76 cm) | Stowed Height9'7" (2.9 m) | Fuel Capacity..... 40 gal (151.4 L) |
| Capacity 500 lbs (227 kg) | Wheelbase 12' (3.7 m) | Hydraulic Capacity..... 65 gal (246 L) |
| Construction.....Steel | Width.....8'6" (2.6 m) | Drive Speed |
| | Ground Clearance 1'1" (33 cm) | Elevated..... 1 mph (1.6 km/h) |
| | Weight..... 30,150 lbs (13,676 kg) | Stowed..... 3 mph (4.8 km/h) |
| | Tire Size..... 15" x 22" (30 cm x 56 cm) | Gradeability (Theoretical)..... 62% |
| | | Horizontal Reach 71'1 1/2" (21.7 m) |

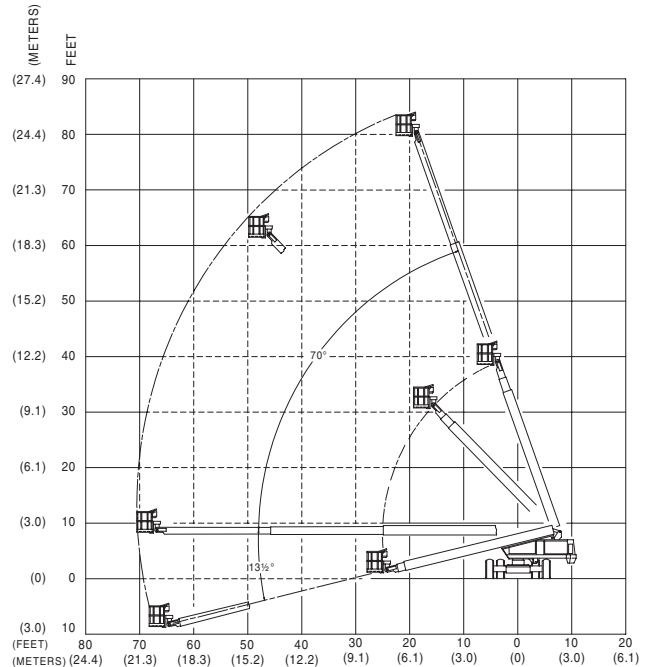
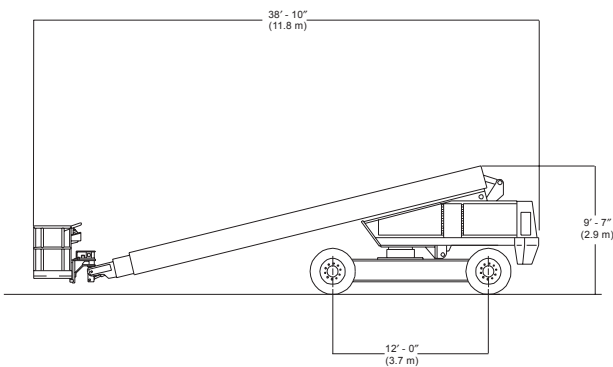

Standard Features

- 360 degree continuous turntable rotation
- Prop. drive, lift, swing & extend
- Engine anti-restart
- Tie down lugs
- 170 degree hydraulic Platform rotation
- 12 volt emergency operated power
- Manual bleed down valve
- Hydraulic oil level/temp gauges
- Foam filled tires
- Driveable at full height
- Tilt alarm
- 125 volt GFCI AC outlet
- Aluminum upper booms
- Hour meter
- High engine temp/low oil pressure shut down
- Lifting lugs
- Extendable rear axes
- Operator Horn
- Four wheel drive

Options

- Platform control box cover
- Flashing light on boom
- Swinging gate
- Sandblast protection kit
- Driving lights
- Dual Fuel
- Platform work lights
- Spark arrestor muffler
- Cold weather start kit
- Hydraulic Sys. Cold weather Warm-up Kit
- Two wheel drive option deduct
- Drive motion alarm
- Tow kit
- Airline to Platform
- AC Generator
- Platform – 60" x 30" (152 x 76 cm) Aluminum 650 lb Cap. (295 kg)
- Platform – 96" x 30" (243.8 x 76 cm) Aluminum 600 lb Cap. (272 kg)

DANGER: Models described in this brochure are NON-INSULATED and do not provide electrocution protection from contact with or close proximity to energized conductors which is pointed out on decals and placards attached to the machine. Only qualified and trained operators are to be authorized to use and operate a work platform. Aerial work platforms must be elevated only on firm, level surface. Products in this brochure comply with applicable ANSI Standards. This literature is for illustrative purposes only. Consult Operating Maintenance and Parts Manuals for proper procedures. Specifications may vary and are subject to change without notice or obligation.

Manufacturing Plant
2009 Roseport Road
Elwood, Kansas 66024
800-255-0317
785-989-3000

Australia
26 Redfern Road
Wetheril Park NSW
2164 Australia
(02) 9725 4000