

# Straight Jib Boom



# TB47J



# Snorkel

[www.snorkelusa.com](http://www.snorkelusa.com)

Snorkel TB47J		
Platform	Machine Dimensions	Performance
Height.....46'6" (14.2 m)	Stowed Length.....26'9" (8.15 m)	Power Source.....Gas or Diesel
Size.....30" x 60" (76 cm x 152 cm)	Stowed Height .....7'1 1/2" (2.4 m)	Fuel Capacity.....20 gal (75.7 L)
Capacity.....500 lbs (227 kg)	Wheelbase.....8' (2.44 m)	Hydraulic Capacity.....25 gal (94.6 L)
Construction.....Steel	Width.....7'11 1/2" (2.4 m)	Drive Speed
	Ground Clearance .....10" (25 cm)	Elevated.....1 mph (1.6 km/h)
	Weight.....13,315 lbs (6,040 kg)	Stowed.....3 mph (4.8 km/h)
	Tire Size.....12" x 16 1/2" (30 cm x 42 cm)	Gradeability (Theoretical).....41%
		Horizontal Reach.....39' (11.9 m)

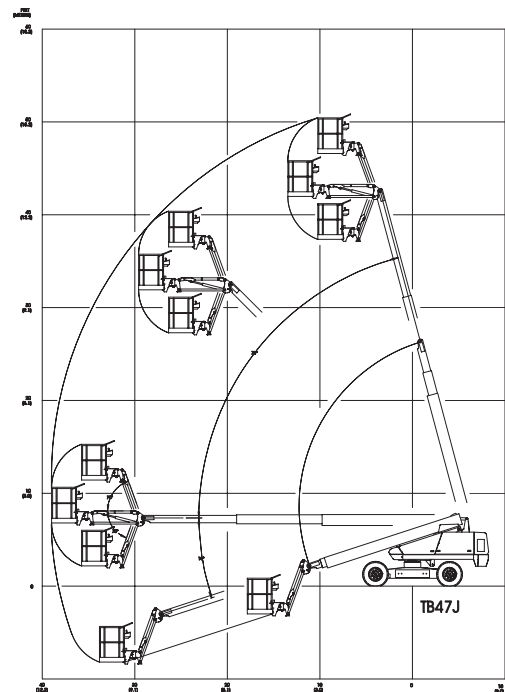
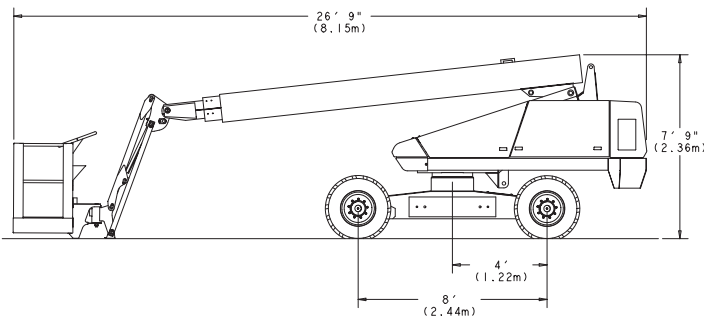

### Standard Features

- 360 degree continuous turntable rotation
- Proportional drive, lift & swing
- Engine anti-restart
- Tie down lugs
- 170 degree hydraulic Platform rotation
- 12 volt emergency operated power
- Manual bleed down valve
- Hydraulic oil level/temp gauges
- Driveable at full height
- Tilt alarm
- 125 volt GFCI AC outlet
- Aluminum upper booms
- Hour meter
- High engine temp/low oil pressure shut down
- Lifting lugs
- Four wheel drive

### Options

- Operator Horn
- Platform control box cover
- Flashing light on boom
- Swinging gate
- Sandblast protection kit
- Driving lights
- Dual Fuel
- Platform work lights
- Spark arrestor muffler
- Cold weather start kit
- AC Generator
- Drive motion alarm
- Foam filled tires
- Tow kit
- Two wheel drive opt. deduct
- Platform – 92" x 30" (234 x 76 cm) Alum. 500 lb Capacity (227 kg)
- Platform – 60" x 30" (152 x 76 cm) Alum. 600 lb Capacity (272 kg)

**DANGER:** Models described in this brochure are NON-INSULATED and do not provide electrocution protection from contact with or close proximity to energized conductors which is pointed out on decals and placards attached to the machine. Only qualified and trained operators are to be authorized to use and operate a work platform. Aerial work platforms must be elevated only on firm, level surface. Products in this brochure comply with applicable ANSI Standards. This literature is for illustrative purposes only. Consult Operating Maintenance and Parts Manuals for proper procedures. Specifications may vary and are subject to change without notice or obligation.

**Manufacturing Plant**  
 209 Roseport Road  
 Elwood, Kansas 66024  
 800-255-0317  
 785-989-3000

**Australia**  
 26 Redfern Road  
 Wetheril Park NSW  
 2164 Australia  
 (02) 9725 4000